

**sapa:**

**buildingsystem**

ARCHITECTURAL ALUMINIUM SOLUTIONS

# Avantis 95



Passive windows

**Sapa Building System**





With the new passive house aluminium window Avantis 95, the benefits of aluminium are combined with the highest thermal insulation for sustainable architecture.



Avantis 95 is the perfect aluminium windows and door system for high rise buildings and resists the most extreme weather conditions:

- $U_w \leq 0,8 \text{ W/m}^2\text{K}$
- WWA classes C5 / E1950 / 4
- blower door  $0,18\text{m}^3/\text{hm}^2$  (50 Pa)

#### Intelligent functionality

» **Maximum thermal insulation: Passive House Suitable Component according to Passive House Institute\* and IFT\*\* with certificate.**



- » Avantis 95 is a robust system: weight vents up to 170 kg
- » **Only 95 mm frame depth which is extremely low for a passive window.**
- » Large size windows are possible: vents up to 2400 mm height and up to 1600 mm wide
- » Triple glazing up to 62 mm
- » Multifunctional in connection details and use of components: plenty of possibilities with limited number of components
- » Wide range of solutions and configurations:
  - turn, turn and tilt, tilt and turn, bottom hung and fixed windows.
  - combination windows

#### Advanced energy saving for a sustainable environment

- » Avantis 95 High weather performance system:
  - Water tightness 1950 Pa
  - WWA classification: C5, E1950, 4 (EN12210 /12208 /12207)
  - extreme low air infiltration of  $0,18\text{m}^3/\text{hm}^2$  at a pressure of 50 Pa (blowerdoor test) where the highest European test claims a value lower than  $1,89 \text{ m}^3/\text{hm}^2$  so a 10 times better result !
- » Thermal value:  $U_w \leq 0,8 \text{ W/m}^2\text{K}$  (1,23 m x 1,48 m, triple glass  $U_g$  0,7, TBT)
- » Mechanical strength: class 4, operating forces: class 1 (EN13155)
- » Avantis 95 includes several weather barriers by means of specially designed gaskets, a large decompression chamber and internal drainage to assure perfect weather resistance.
- » Effective water evacuation is ensured via punched drain holes.
- » Special finishing profiles provide additional building drainage.
- » Acoustic performance is greatly enhanced with multiple gaskets.

The Passive House Institute (PHI) is an independent research center that has played an especial crucial role in the development of the passive House concept- the World only performance-based energy standard in construction. The Passivhaus-Institut is responsible for promoting and maintaining the Passive House - Passivhaus building program

ift Rosenheim is an internationally acting scientific service provider for manufacturers of windows, curtain walls, glass, pedestrian, industrial and commercial doors and gates and all accessories. ift Rosenheim performs tests for the fitness for use of building components and various materials depending on their field of application.



### Very easy to manufacture and install

- » The **Avantis 95 system is based on the classical window design principle and doesn't require any additional fabrication steps. It can be constructed as a normal window, resulting in smooth, fast and easy implementation in your production.**
- » Fast and traditional on-site installation
- » Limited number of profiles and accessories but endless combinations
- » Crimp, pin or eccentric cleats
- » Standard or hidden hardware
- » Several components used out of the Avantis range
- » Modular punch tool system: dedicated punching tools for all machining
- » CNC programming available in Sapalogic

### Attractive design

- » The slim sightline and modern look make the Avantis 95 a particular attractive system
- » When it comes to design, there are no limits the way architectural demands can be met
- » Optimum proportion between stability and sightline
- » Hidden drainage or coated drainage caps possible
- » A comprehensive range of supplementary finishing profiles allows the fenestration to be integrated perfectly into the building.
- » Vent, frame and transom profiles are available in a range of dimensions to meet the needs of stability and design requirements.
- » A wide choice of hinges, handles and hardware finalise your specific needs.
- » Designer glazing beads add extra finish.

### Enhanced security

- » The combination of safety glass and special hardware such as multipoint locking ensures a high resistance against forced entry. Internal tubular glazing beads prevent unclipping from the outside.
- » Anti-burglary: class 2 (certification ongoing)
- » A wide range of locking and non-locking handles are integrated in to the system.



Avantis 95 is as easy to fabricate as any normal aluminium window system. No special accessories, tools or techniques are required.

### Avantis 95 SHI

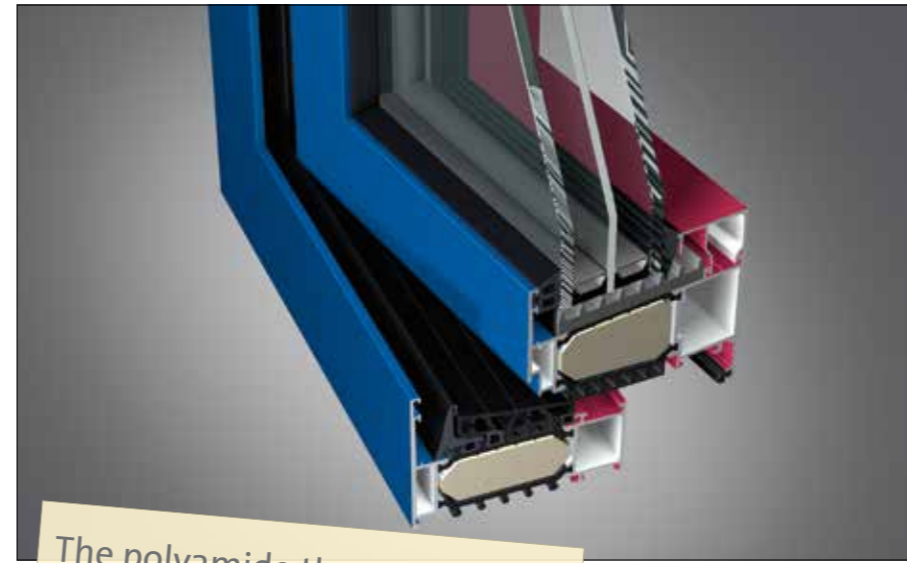

The polyamide thermal break allows bi-colour finishes. As a result, the exterior building requirements do not infringe interior design requests.



### Finishes

- » Over 400 powder coated paint colors in matt, gloss or satin.
- » Unique wood effect, textured and textured metallic ranges are available.
- » Anodised finish is also an option.
- » Accessories can be supplied in corresponding colors to match the profiles.
- » Our surface finishes meet the highest standards of Qualicoat or Qualanod.

### Green environment

- » All profiles are easily cleaned
- » Aluminium does not rust, rot or tear and the shape will not deform
- » Aluminium is a "green" product: it can be recycled infinitely without quality loss

### Project support & service

- » Sapa Building System's experienced Project Team will advise you on the best product solutions.
- » We can help you with pricing, strength calculations, building connections, thermal simulations, etc..
- » Specific project solutions can be developed.
- » Samples, catalogues, technical specifications and digital drawings are available.

**Sapalogic** (or Orgadata, MAP) is a user-friendly calculation program for fast, efficient and complete calculation of windows, doors, structures, curtain walls and conservatories. SapaLogic is very much complete but modular still: the different versions can be adapted to your company's needs.

**SapaThermic** is detailed thermal simulation software for doors, windows, sliding systems and curtain walls. It can either be linked to SapaLogic or act as a stand-alone version.

## Applications

Windows



----- : inward opening

## Dimensions

Min. sightline fixed frame	68 mm
Min. sightline window with inward opening vent	119 mm
Min. sightline transom	98 mm
Profile depth frame / Building depth	95 mm
Profile depth vent	105 mm
Max. window (width x height)	1600 x 2400 mm

## Glazing

Rebate height vent / frame	22 / 30 mm
Infill thickness	36 - 62 mm
Glazing method	dry glazed with EPDM gaskets or silicon

## Performances

Thermal break	60 mm tubular shaped polyamides PA 6.6 GF25		
Thermal insulation	EN ISO 10077-2		
Frame insulation	$U_f = 0,69-0,91 \text{ W/m}^2\text{K}$		
Window insulation (turn, turn-tilt window)	$U_w = 0,80 \text{ W/m}^2\text{K}$ , $U_{w,installed} = 0,84 \text{ W/m}^2\text{K}$		
	with certificate The Passivhouse Institute ( $U_g = 0,7 \text{ W/m}^2\text{K}$ , 1230x1480, Swisspacer V)		
Window insulation (turn, turn-tilt window)	$U_w = 0,78 \text{ W/m}^2\text{K}$ , $U_{w,installed} = 0,78 \text{ W/m}^2\text{K}$		
	with certificate Ift Rosenheim ( $U_g = 0,6 \text{ W/m}^2\text{K}$ , 1230x1480, Swisspacer V)		
Fixed window	$U_w = 0,77 \text{ W/m}^2\text{K}$ ( $U_g = 0,7 \text{ W/m}^2\text{K}$ , Swisspacer V, 1230x1480)		
	$U_w = 0,70 \text{ W/m}^2\text{K}$ ( $U_g = 0,6 \text{ W/m}^2\text{K}$ , Swisspacer V, 1230x1480m)		
Air permeability	4	600 Pa	EN 12207
Water tightness	E1950	1950 Pa	EN 12208
Wind resistance, security test	C5	2000 Pa, security 3000 Pa	EN 12210
Acoustic insulation	certification ongoing		EN ISO 717/1
Forced entry resistance	class 2 (certification ongoing)		ENV 1627 - 1630

This information is only an indication. For more information, please consult your local Sapa Building System branch.

## Technical drawings

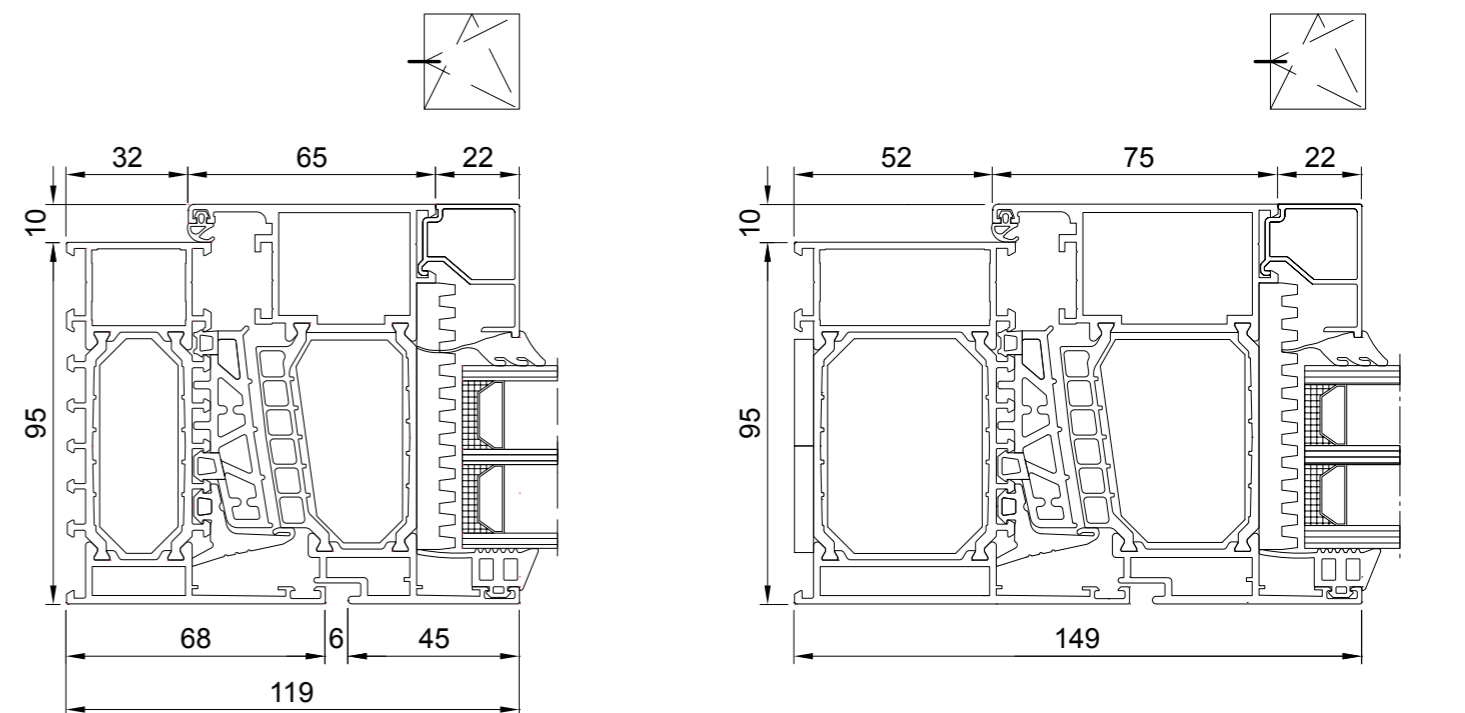
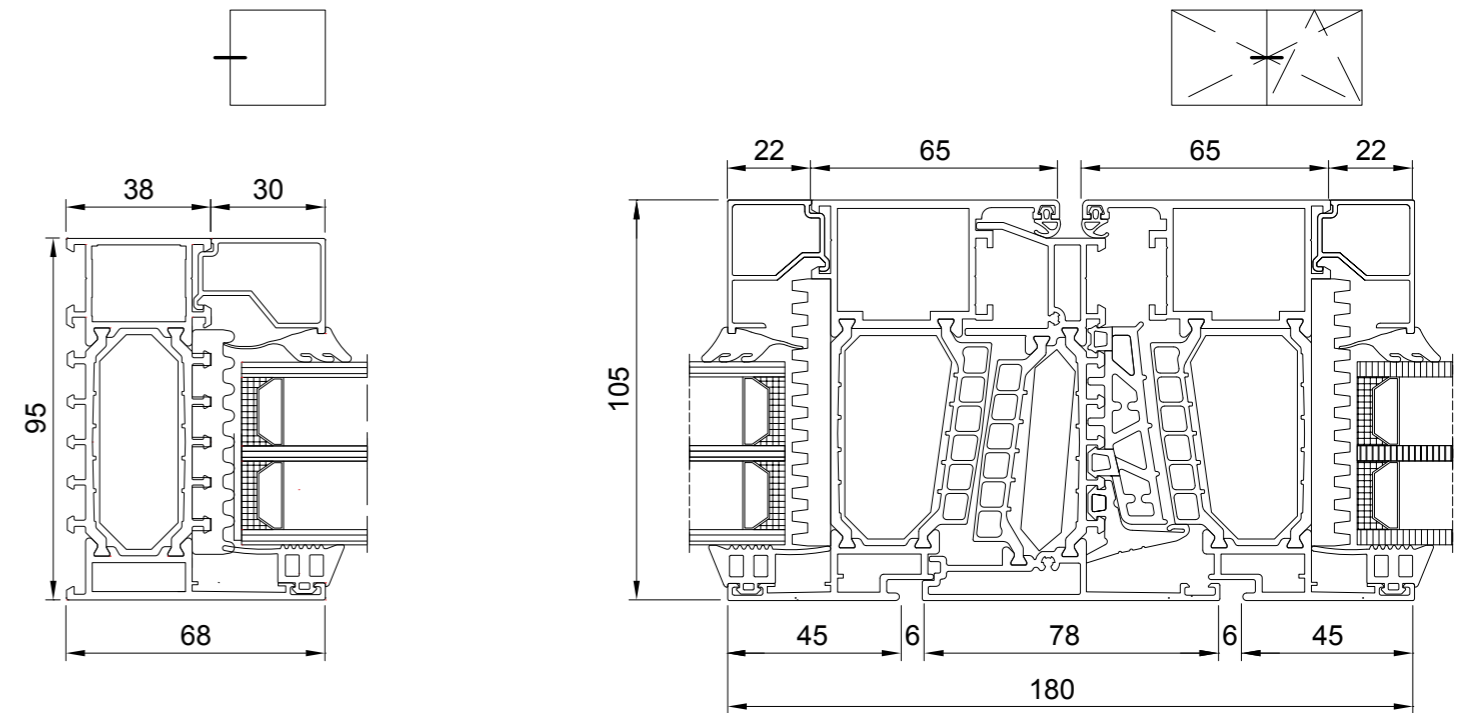

**Sapa Building System**, is one of the largest suppliers of aluminium building systems in Europe and is part of the Swedish group Sapa. The core business is the development and distribution of aluminium profile systems. Sapa Building System aims for well-developed systems and project solutions offering a tangible added value to fabricators, architects, investors and home-owners.

**Windows and Doors**

**Sliding Systems**

**Curtain Walls**

**Conservatories**

**Balustrades, gates and others**

**BIPV**

Your local Sapa Building System fabricator

**Sapa Building System NV**

Postal address **Industrielaan 17, BE-8810 Lichtervelde** Tel. **+32 51 72 96 66** Fax **+32 51 72 96 89**

Postal address **Industriezone Roosveld 11, BE-3400 Landen** Tel. **+32 11 69 03 11** Fax **+32 11 83 20 04**

E-mail [info.be@sapagroup.com](mailto:info.be@sapagroup.com) Website [www.sapabuildingsystem.com](http://www.sapabuildingsystem.com)

**sapa:**

**buildingsystem**

ARCHITECTURAL ALUMINIUM SOLUTIONS